

BLACK SERIES AIR INTAKE SYSTEM

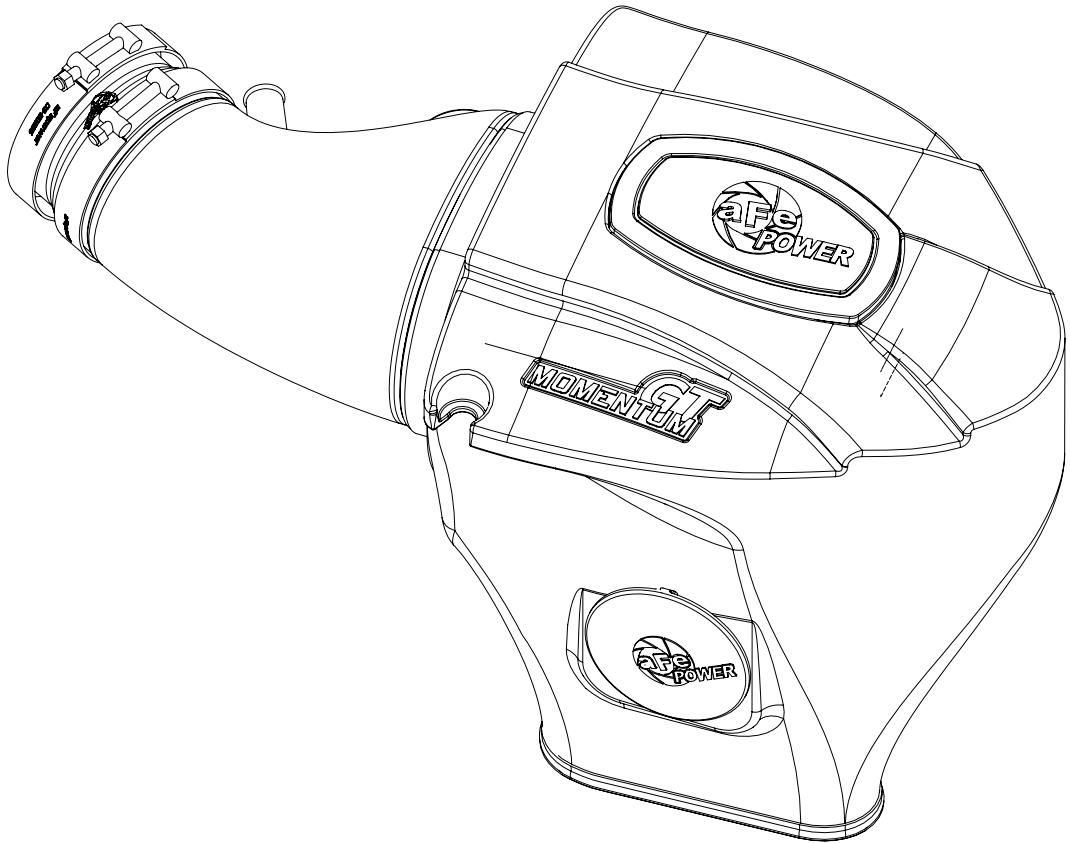

advanced FLOW engineering Black Series Cold Air Intake System

Instruction Manual P/N: 58-10003D / 58-10003R

Make: Dodge	Model: Challenger SRT/SRT-8	Year: 2011-2020	Engine: V8-6.4L HEMI
Make: Dodge	Model: Charger SRT/SRT-8	Year: 2011-2020	Engine: V8-6.4L HEMI
Make: Chrysler	Model: 300 SRT/SRT-8	Year: 2012-2014	Engine: V8-6.4L HEMI



- Please read the entire instruction manual before proceeding.
- Ensure all components listed are present.
- If you are missing any of the components, call customer support at 951-493-7100.
- Ensure you have all necessary tools before proceeding.
- Do not attempt to work on your vehicle when the engine is hot.
- Disconnect the negative battery terminal before proceeding.
- Retain factory parts for future use.

Label	Qty.	Description	Part Number
A1	1	Air Filter (Pro DRY S)	21-91092
A2	1	Air Filter (Pro 5R)	24-91092
B	1	Tube	05-72203C1
C	1	Housing	05-72201C2
D	1	Plug, Air Box	05-01361
E	1	Coupling, Silicone Reducer	05-01358
F	1	Clamp, T-bolt (4-1/16" - 4-3/8")	03-50262
G	1	Seal, Trim: 7/16" (21" inches)	05-00072
H	1	Hose, Silicone Breather: 3/4"ID	05-01475
I	1	Clamp, T-bolt (3-13/16" - 4-1/8")	03-50265
J	1	Black Series Plate	06-00142

Installation will require the following tools:

8mm and 11mm nut driver or socket and flat screw driver.

Note: Legal in California for use on race vehicles only. The use of this device on vehicles used on public streets or highways is strictly prohibited in California and others states that have adopted California emission regulations.

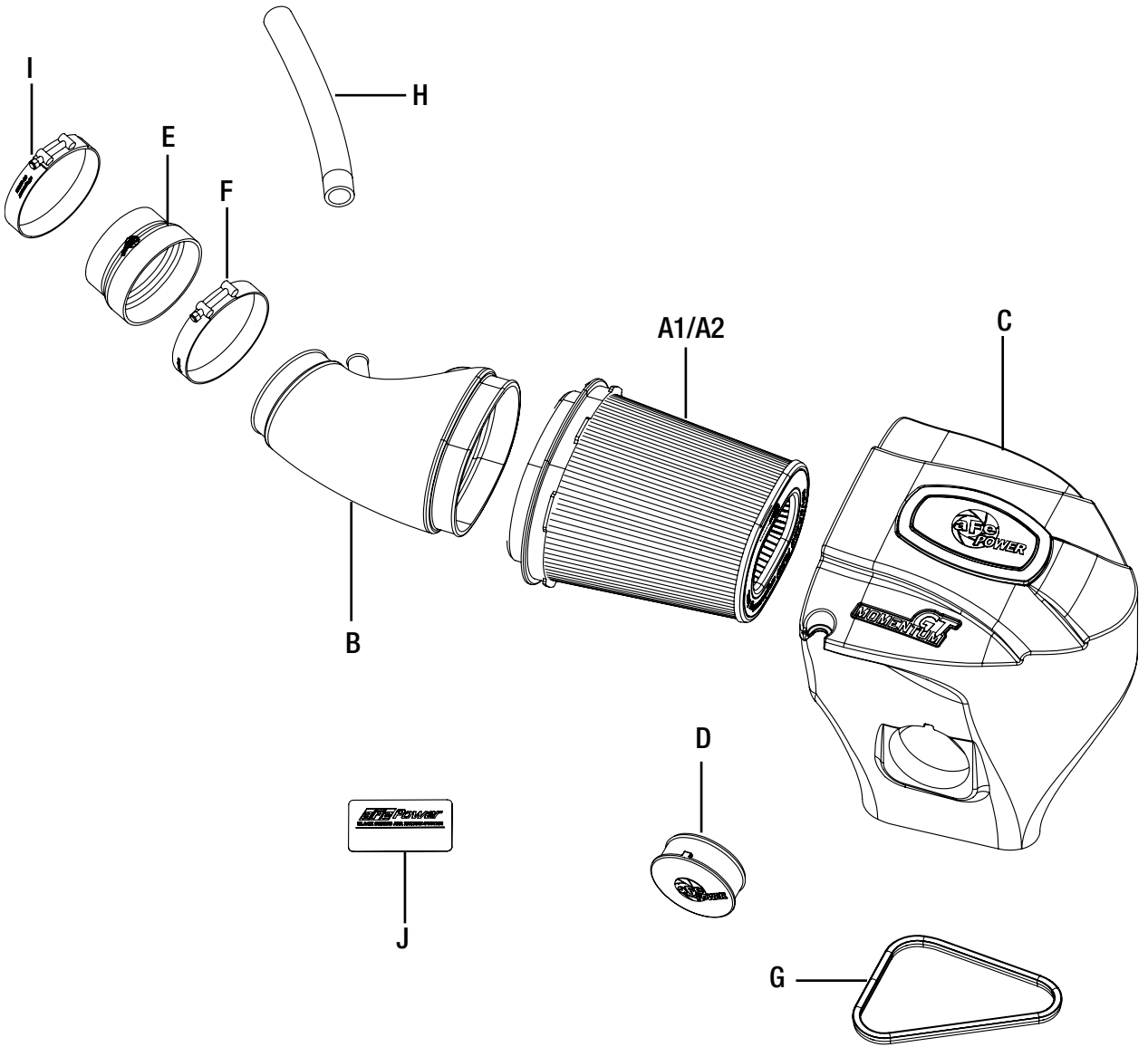



Refer to Figure A for Steps 1-5

Step 1: Remove 8mm bolt from the factory air box.

Step 2: Loosen clamp securing the intake tube to the throttle body.

Step 3: Unplug Temp sensor.

Step 4: Remove driver side engine cover, and remove crank case hose.

Step 5: Pull the factory intake air system out of engine bay.

**Figure B****Refer to Figure B for Steps 6-8**

Step 6: Transfer the grommet from the factory air box to the aFe POWER housing.

Step 7: Install the trim seal on the bottom edge of the aFe POWER housing.

Step 8: Slide the aFe POWER filter inside the aFe POWER housing until it locks in place. Install clamp on the filter end, but do not tighten at this time.



Figure C

Refer to Figure C for Step 9

Step 9: For the 2015+ Challenger, if you wish to use the headlight inlet duct, pop the cap off the center of the headlight and install on the aFe housing the aFe inlet duct (Sold Separately, P/N: 54-72203-SF). For all other vehicles, leave the housing inlet open to get more air or close it off with the furnished plug to block off the hot engine air.



Refer to Figure D for Steps 10-12

Step 10: Make sure factory grommet is installed correctly into hole.

Step 11: Install aFe POWER housing assembly into vehicle.

Step 12: Install coupling with clamps over the throttle body. Do not tighten yet.



Figure E

Refer to Figure E for Steps 13-14

Step 13: Remove the temperature sensor from the factory tube. Secure it into the aluminum fitting by turning clockwise.

Step 14: Install furnished hose onto aFe POWER tube.



Figure F

Refer to Figure F for Steps 15-18

Step 16: Install the tube in the vehicle by sliding it first into the filter then into the coupling.

Step 17: Connect the crank case hose to the valve.

Step 18: Align tube correctly, then tighten all clamps.



Refer to Figure G for Steps 18-21

Step 18: Re-connect the temperature sensor.

Step 19: Re-install the factory bolt removed at Step 1 to secure the housing.

Step 20: Re-install the valve cover.

Step 21: Install the aFe POWER Black Series plate on a flat surface where desired. Your installation is now complete! Thank you for choosing aFe POWER.

NOTE: Check all bolt, clamps, and connectors after 100-200 miles.

PAGE LEFT BLANK INTENTIONALLY



PAGE LEFT BLANK INTENTIONALLY

PAGE LEFT BLANK INTENTIONALLY



Pro DRY S Air Filter



P/N: 21-91092

Pro 5R Air Filter



P/N: 24-91092

Pro DRY S Restore Kit



P/N: 90-59999

Blue Squeeze Restore Kit



P/N: 90-50501

Pre-Filter



P/N: 28-10283

Dynamic Air Scoop



P/N: 54-72203-SF (Carbon)

Twisted Steel Headers



P/N: 48-42002

Throttle Body Spacer



P/N: 46-32007

Cat-Back Exhaust System



P/N: 49-32062
(Challenger Only!)

Sprint Booster V3



P/N: 77-12002

Exhaust Connection Pipes



P/N: 48-32015-YC (Street)
48-32015-YN (Race)

Oil Filter



P/N: 44-LF025

To purchase any of the items above, view airflow charts, dyno graphs, photos, and video; please go to aFepower.com.

Warranty

General Terms:

- aFe warrants their products to be free from manufacturer's defects due to workmanship and material.
- This warranty applies only to the original purchaser of the product and is nontransferable.
- Proof of purchase of the aFe product is required for all warranty claims.
- Warranty is valid provided aFe instructions for installation and/or cleaning were properly followed.
- Proper maintenance with regular inspections of product is required to insure warranty coverage.
- Damage due to improper installation, abuse, unauthorized repair or alteration is not warranted.
- Incidental or consequential damages or cost, including installation and removal of part, incurred due to failure of aFe product is not covered under this warranty.
- All warranty is limited to the repair and/or replacement of the aFe part. To request Return Goods Authorization ("RGA"), email RGA@afepower.com or call (951)493-7100. Upon receipt of the RGA, you must return the product to the address provided in the RGA, freight prepaid and accompanied with a dated proof of purchase and the RGA. Upon receipt of the defective product and upon verification of proof of purchase, aFe will either repair or replace the defective product within a reasonable time, not to exceed thirty days.

Product Category	P/N Prefix	Warranty duration
Direct OE Replacement Filters	10, 11, 30, 31, 71, 73	Life of the vehicle
Racing Filters	18	1 year
Universal	21, 23, 24, 72	2 years
Air Intake Systems	50, 51, 54, 55, 56, 58, 75	2 years
Exhaust Systems	49	2 years
Intercoolers & Intercooler Tubes	46-2	2 years
Intake Manifolds	46-1	2 years
Differential Cover	46-7	Life of the vehicle
Exhaust Manifolds	46	2 years
Throttle Body Spacers	46-3	2 years
Fluid Filters	44	90 days
Pre-Filters	28	2 years
Heavy Duty OE Replacement	70	2 years
PowerSports OE Replacement	81, 87	2 years
PowerSports Intake Systems	85	2 years

No other warranty expressed or implied applies nor is any person or advanced FLOW engineering authorized to assume any other warranty. Some States do not allow the exclusion or limitation of incidental or consequential damages or do not allow limitations on how long an implied warranty lasts, so the above limitations or exclusions may not apply to you. This warranty gives you specific legal rights, and you may also have other rights which vary from State to State.

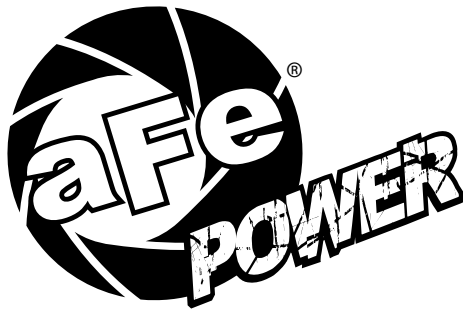

advanced FLOW engineering, inc.
252 Granite Street Corona, CA 92879
TEL: 951.493.7100 • TECH: 951.493.7134
E-Mail: Tech@aFepower.com