

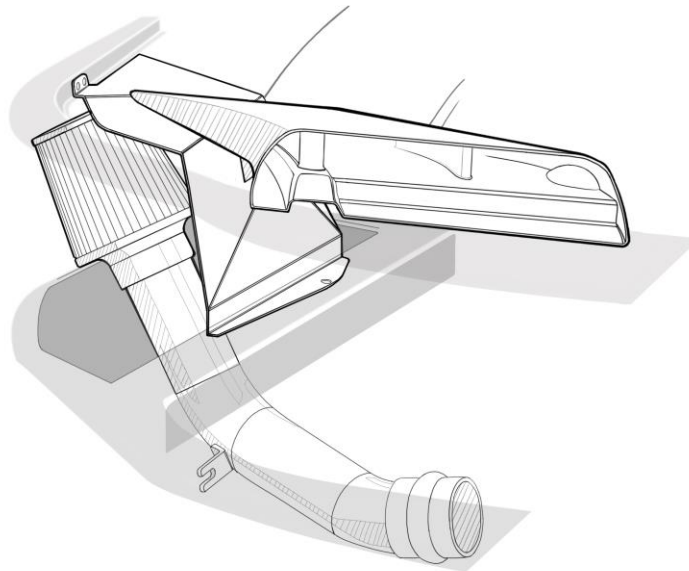

GrimmSpeed Install Guide Series
Installing the GrimmSpeed 2015+ WRX StealthBox Intake
Updated 10/10/15



Introduction: This guide will illustrate the installation of the GrimmSpeed FA20DIT WRX StealthBox Intake system. The difficulty here is **medium**, so take your time and enjoy the job! Expect to spend **45-60min**, depending on level of experience.

Tools: The tools listed below are suggested for this task. Optional tools are noted.

- Flathead and phillips screwdrivers
- 10mm socket and accompanying extensions/ratchet
- 5/16in socket
- 3mm allen wrench

Tips: Take care to follow the installation instructions very carefully when installing the filter onto the intake tube. This measurement is quite important and will ensure that the MAF sensor reads accurately!

Procedure:

1. Begin by collecting your tools and popping your hood.

2. Remove the factory snorkel if your vehicle is equipped by releasing the two small pop clips near the front.



3. Next, disconnect the MAF sensor from the MAF harness.



4. Using your 10mm socket, remove the two 10mm nuts at the top of the factory airbox bracket. Set these aside, as they will be reused.



5. Using your 10mm socket and extension, remove the 10mm bolt that secures the bottom of the factory airbox. Set this aside, as you will be reusing it also.

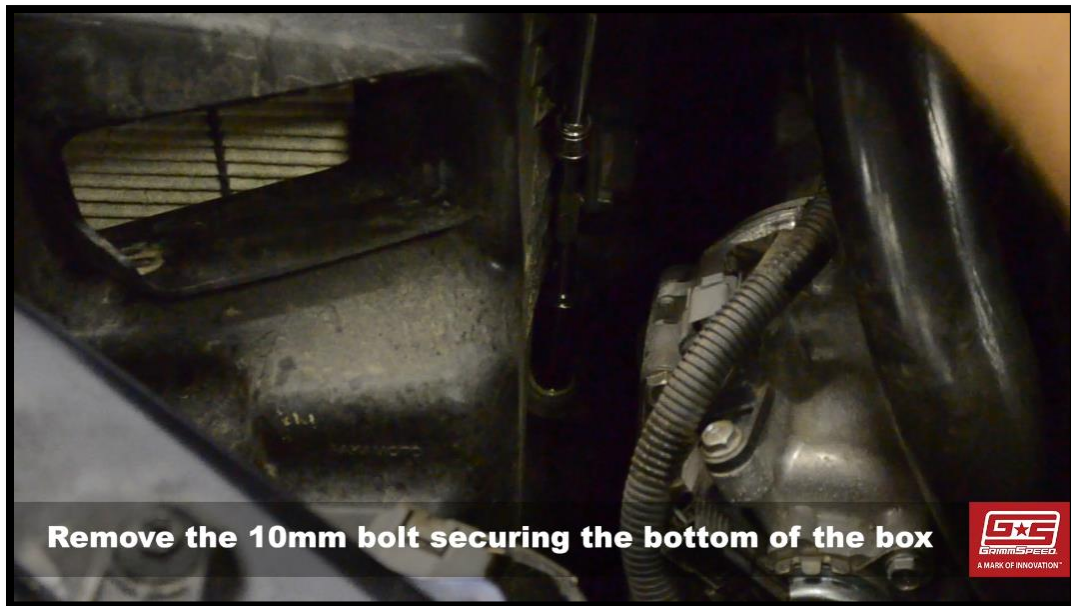

6. Release the clips on the top of the factory airbox and remove the front portion along with the filter, to make space in the engine bay.



7. Reaching down with your 10mm socket, remove the 10mm nut securing the factory intake tube to the support bracket behind the front bumper. Keep this nut, as we'll reuse it in a bit.

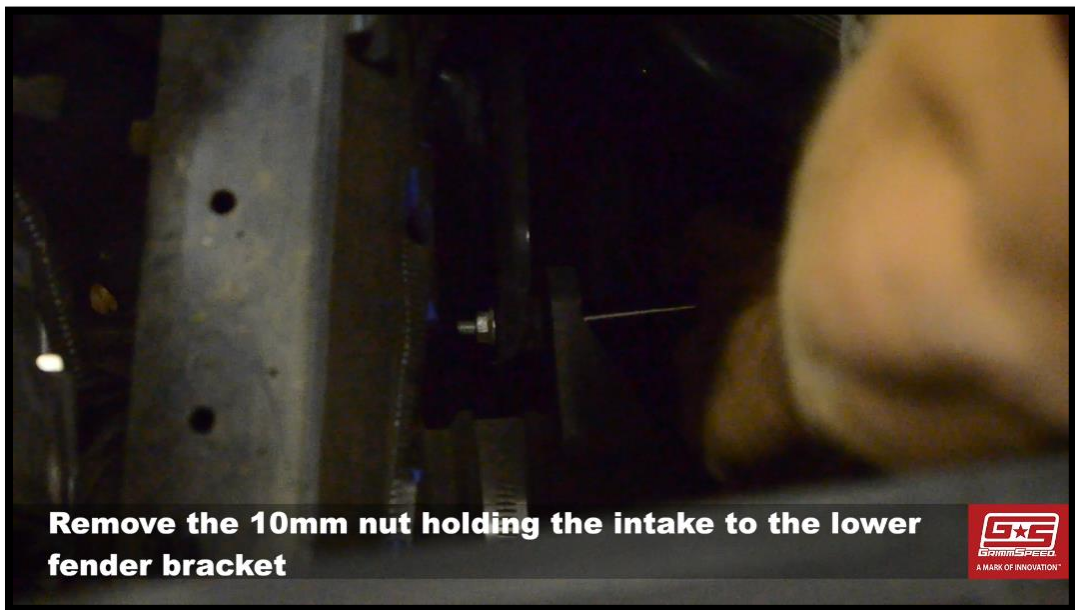

8. Reach down behind the passenger side radiator fan and unclip the power harness from the bottom corner.



9. Next, there are two 10mm bolts holding the top of the passenger side radiator fan in place. Locate these and then remove them both. At this point, the fan is completely disconnected and can carefully be maneuvered out of the engine bay.



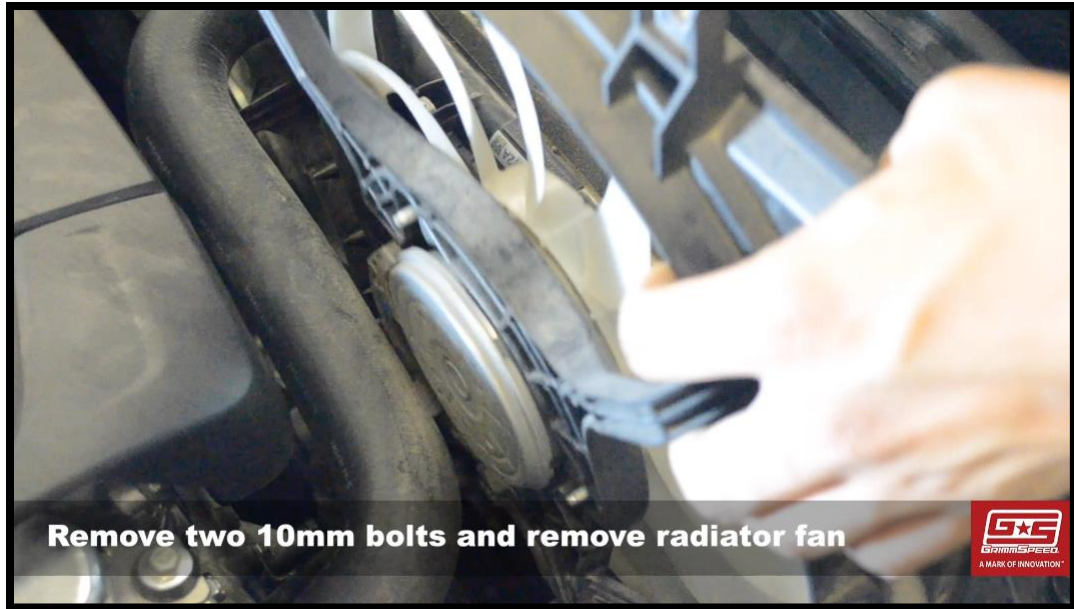

10. This is a difficult step to show in photos, but in the image below, you'll see an arrow identifying the worm gear clamp that secures your factory intake to the plastic turbo inlet. You'll want to use your 5/16in socket and loosen this clamp so that the factory intake can be removed.

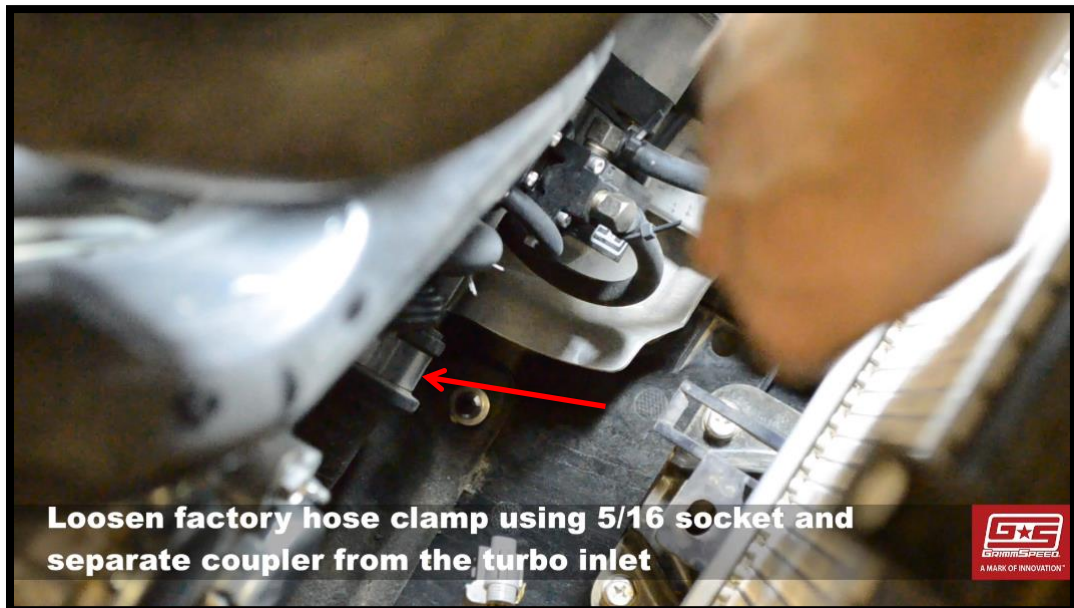

11. With the bottom portion of the factory intake separated from the plastic turbo inlet, you can now move back to the remaining portion of the airbox and maneuver it out of the engine bay. You'll need to do some twisting and take advantage of the accordion flexible sections.



12. Install the provided gasket strips to the GrimmSpeed StealthBox heat shield. Begin with the middle length in the location shown below. The longer strip is used on the opposite side of the two mounting holes. The shortest piece is meant to be used around the port where the snorkel is inserted later. It's a very snug fit, to keep as the filter as isolated as possible from the hot engine bay air.



13. Next, remove the factory MAF sensor from the stock intake using a screwdriver. Put the screws back into the intake for safe keeping. We will not be needing them.



14. Reinstall your MAF sensor into the new GrimmSpeed tube using the included machine screws and your 3mm allen wrench. The MAF can only be installed in one direction, so there's no need to worry about accidentally installing it backwards.



15. **IMPORTANT:** The GrimmSpeed intake is very carefully designed to make use of the velocity stack that we've integrated into the air filter. For this reason, it's very important that when installing the filter, that it's only installed 1" onto the tube. If your intake doesn't have the integrated stopper, use a ruler and a marker or piece of tape to make a note of where 1" from the end of the tube is (see arrow below).

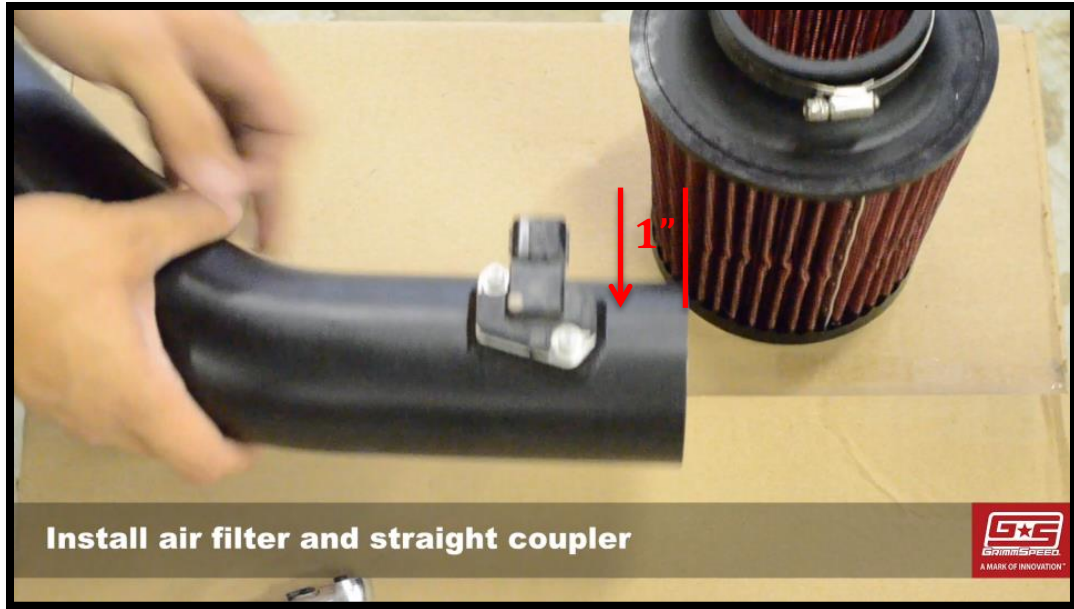

16. Finally, use your 5/16" socket to tighten the filter onto the intake tube, ensuring that it is straight.

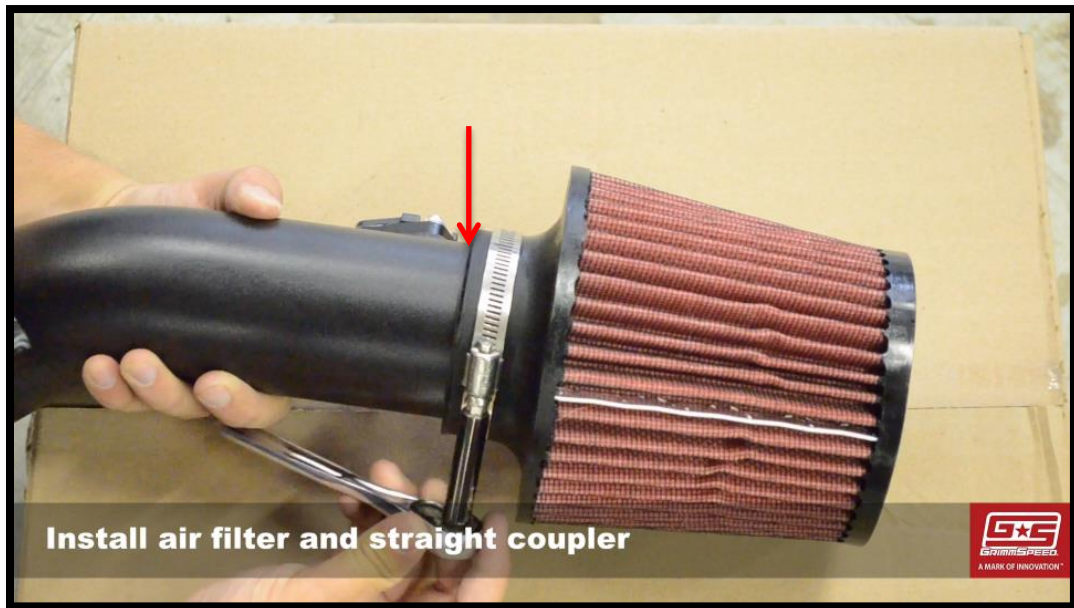

17. Now is also a good time to install the included hump hose coupler onto the opposite end of the tube. Much like the filter, there's no need to install this any further onto the tube than is needed for the worm gear clamp.

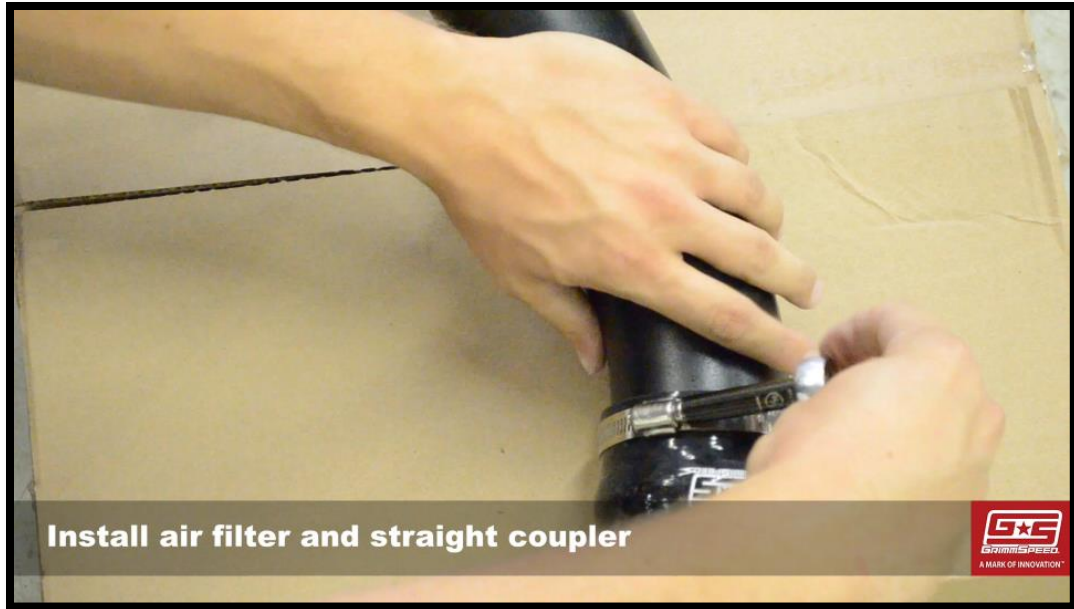

18. Maneuver the GrimmSpeed intake into place where the stock intake once sat.



19. Reach down and slip the included worm gear clamp over the opposite end of the hump hose coupler loosely and slip the GrimmSpeed intake into place on the plastic turbo inlet. Do not tighten this coupler yet – we want some wiggle room for the next step.



20. Reinstall the 10mm nut onto the factory support bracket behind the bumper. Be sure to use the nut that has the larger flange, as it's very similar to the two that we'll use on the heatshield, but the larger flange is needed. If your third nut doesn't have a larger flange, use the included washer.

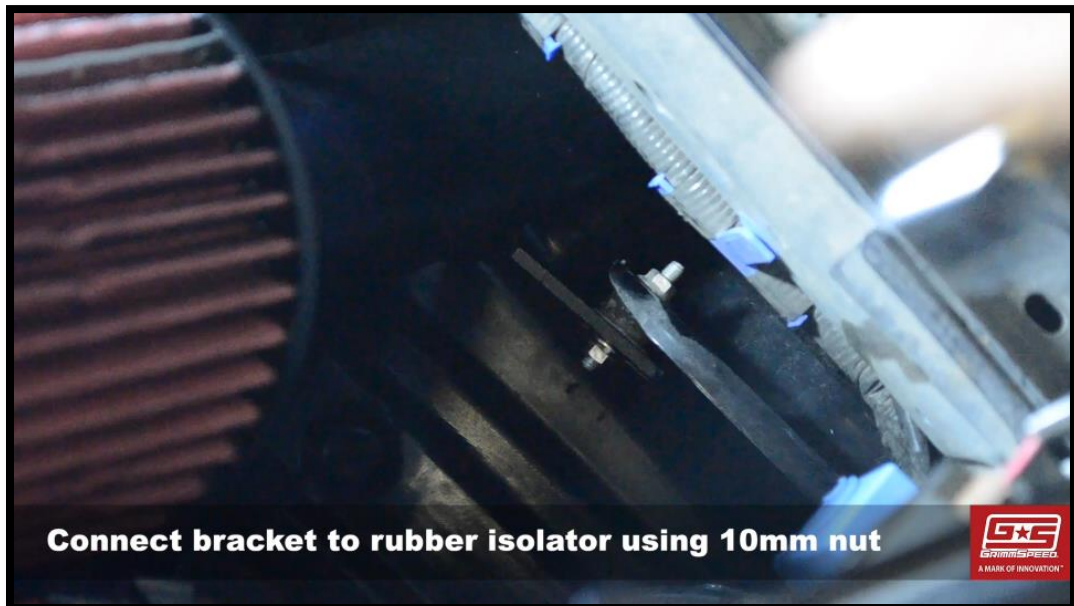

21. Now you can reach back down and tighten the hose clamp at the turbo inlet. Be sure to check your filter placement before doing so and make small adjustments so that it isn't resting on anything and then go ahead and tighten this last clamp.

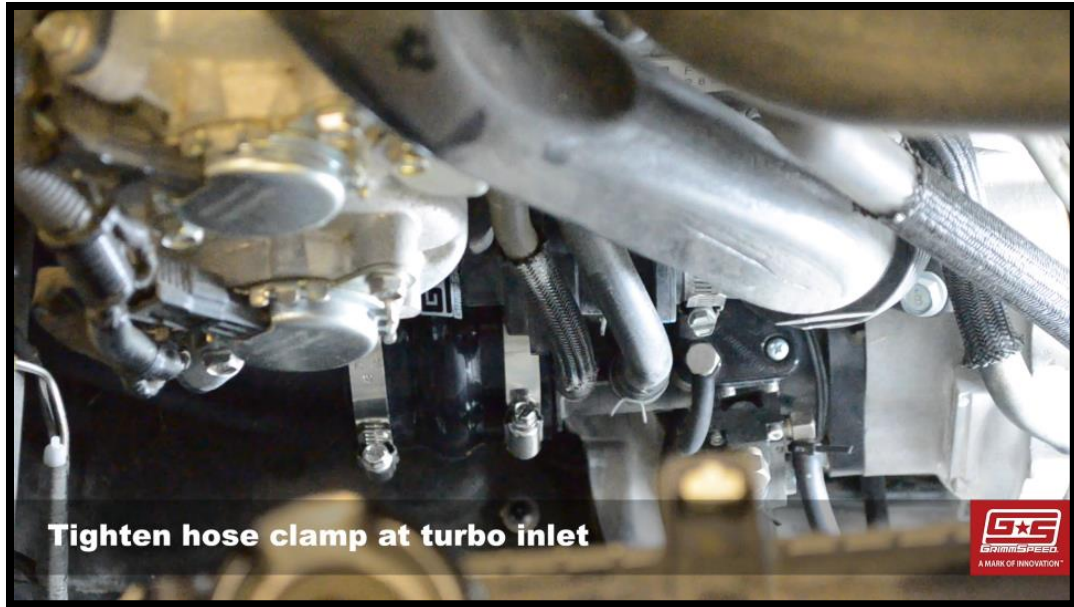

22. Go ahead and reinstall your passenger side radiator fan. It'll slip into two slots at the bottom and then rest right in place. Use the two 10mm bolts that you originally removed. **BE SURE TO RECONNECT THE WIRING HARNESS.**

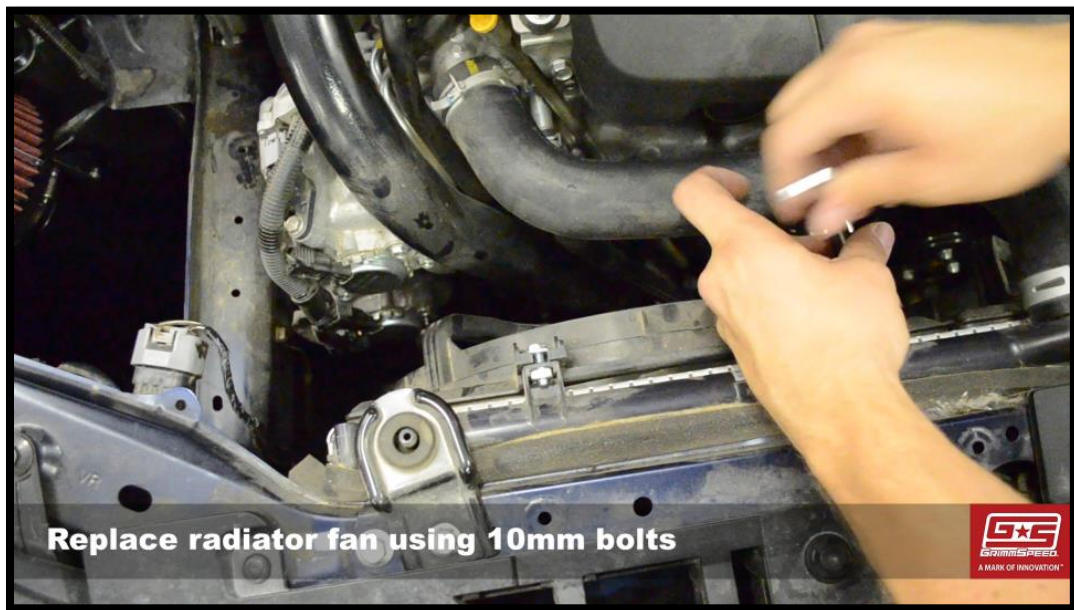

23. Connect the GrimmSpeed MAF harness extension to your factory harness and then to the MAF sensor in the intake tube. Route the harness such that it is nicely tucked to the side.



24. Next, install the GrimmSpeed StealthBox heat shield over the filter. Use the two 10mm nuts to secure the top of the heat shield and the single 10mm bolt at the base.





25. Finally, reinstall the factory snorkel such that it feeds the StealthBox heat shield with fresh air. It may help to lubricate the rubber gasket with a small amount of soapy water, but once it's in place, it should fit snug and create a great seal. Use the two factory clips towards the front of the snorkel to secure it.



26. Lastly, get in touch with your tuner and schedule a proper tune!



TUNING NOTE: Please note that a tune is required for this intake and it is not recommended that you operate the vehicle without a proper tune. Off-the-

shelf maps not specifically for the GrimmSpeed intake are not approved for use.

That's it! You should be all set to go. Check the assembly periodically to make sure everything is still snug.

Don't hesitate to contact us directly with any questions!

Sales@GrimmSpeed.com | 612-379-0000