

Instruction Manual

25-305BK AEM HIGH CAP UNIVERSAL FUEL PRESSURE REGULATOR



Read and understand these instructions **BEFORE** attempting to install this product.

- Do not smoke while working on the fuel system.
- Keep open flames or sparks away from your work area.
- Be sure to relieve fuel pressure before beginning the installation.

Kit Contents

Quantity	Description
1	Universal Pressure Regulator
1	Bracket, Universal Pressure Regulator
4	Screw, Flat Head Cap 10-32x1/2"

Optional Fittings

AEM Part Number	Description
50-200-06	-6 Male AN to 9/16"-18 Male ORB (O-Ring Boss)
50-200-86	-8 Male AN to 9/16"-18 Male ORB (O-Ring Boss)

Installation & Adjustment

1. Installation of the AEM Universal Fuel Pressure Regulator

Warning!!!: Due to the differences on vehicle fuel pressure on different applications it is **highly recommended** that you adjust the fuel pressure on your vehicle. All adjustments of the pressure regulator will be explained in a later portion of the instructions

- The AEM universal fuel pressure regulator is designed with the mounting bracket as a bolt on component to the regulator body. If you desire, the regulator can be bolted directly to the car using the four threaded holes at the back of the regulator which are tapped with a 10-32 thread.
 - Install the mounting bracket to the regulator using the four supplied allen head screws.
 - Mount the fuel regulator on a flat surface.
 - The diameter of the mounting holes on the bracket are 1/4". On the last page of the instructions will be a mounting template, which should be used to mount the fuel regulator.
- The two inlet ports are tapped with a 9/16-18 thread for use with o-ring fittings. The fuel pressure gauge port is tapped with a 1/8-27 NPT.
- The outlet port is located at the bottom of the fuel pressure regulator. It has a 9/16"-8 thread for use with o-ring fittings.
- Connect the vacuum hose to the top of the fuel pressure regulator. (Hose size is a 3/16" or 5 mm)
- Connect the negative battery terminal.
- Turn the ignition or fuel pump switch to the on position for approximately two seconds. **Do not operate the starter.** Then turn the ignition switch to the off position.

2. Adjustment

Note: The AEM adjustable fuel pressure regulator can be fine-tuned for your application. These adjustments will be covered in this section. A fuel pressure gauge needs to be used for precise tuning.

- When fuel pressure adjustments are to be made, loosen the jam nut on the top of the AEM fuel pressure regulator and either tighten or loosen the set screw.
 - When loosening the jam nut a 7/16" wrench should be used.
 - When tightening or loosening the set screw a 1/8" allen key should be used.
 - To increase fuel pressure, turn the set screw in a clockwise rotation.
 - To decrease fuel pressure, turn the set screw in a counter-clockwise rotation.

Instruction Manual

25-305BK AEM HIGH CAP UNIVERSAL FUEL PRESSURE REGULATOR



Drawings

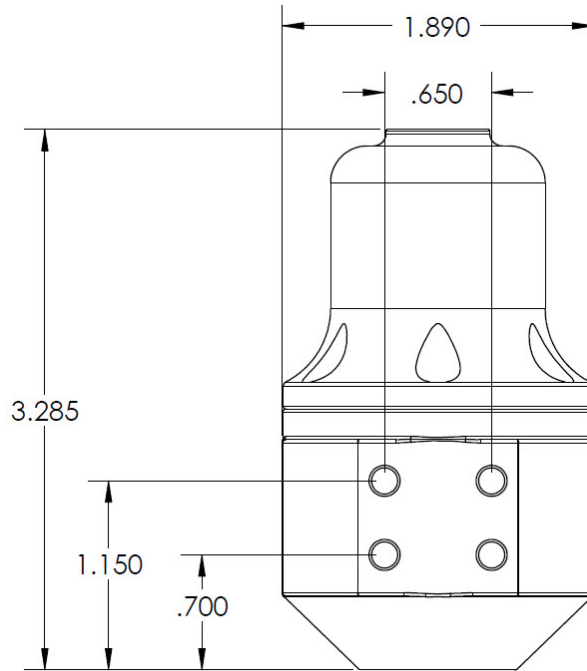
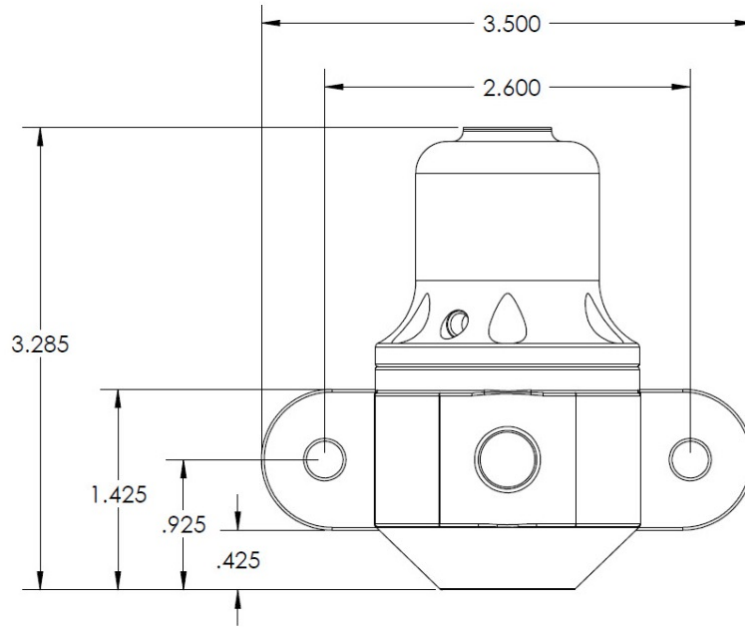

Instruction Manual

25-305BK
AEM HIGH CAP UNIVERSAL FUEL
PRESSURE REGULATOR



12 Month Limited Warranty

Advanced Engine Management Inc. warrants to the consumer that all AEM High Performance products will be free from defects in material and workmanship for a period of twelve (12) months from date of the original purchase. Products that fail within this 12-month warranty period will be repaired or replaced at AEM's option, when determined by AEM that the product failed due to defects in material or workmanship. This warranty is limited to the repair or replacement of the AEM part. In no event shall this warranty exceed the original purchase price of the AEM part nor shall AEM be responsible for special, incidental or consequential damages or cost incurred due to the failure of this product. Warranty claims to AEM must be transportation prepaid and accompanied with dated proof of purchase. This warranty applies only to the original purchaser of product and is non-transferable. All implied warranties shall be limited in duration to the said 12-month warranty period. Improper use or installation, accident, abuse, unauthorized repairs or alterations voids this warranty. AEM disclaims any liability for consequential damages due to breach of any written or implied warranty on all products manufactured by AEM. Warranty returns will only be accepted by AEM when accompanied by a valid Return Merchandise Authorization (RMA) number. Product must be received by AEM within 30 days of the date the RMA is issued. UEGO oxygen sensors are considered wear items and are not covered under warranty. Please note that before AEM can issue an RMA for any electronic product, it is first necessary for the installer or end user to contact the EMS tech line at 1-800-423-0046 to discuss the problem. Most issues can be resolved over the phone. Under no circumstances should a system be returned or a RMA requested before the above process transpires. AEM will not be responsible for electronic products that are installed incorrectly, installed in a non-approved application, misused, or tampered with. Any AEM electronics product can be returned for repair if it is out of the warranty period. There is a minimum charge of \$50.00 for inspection and diagnosis of AEM electronic parts. Parts used in the repair of AEM electronic components will be extra. AEM will provide an estimate of repairs and receive written or electronic authorization before repairs are made to the product.